

# PRODUCT DATA

COMFORT CT150 / CT200 BY NILAN



## Ventilation & passive heat recovery



Domestic



Passive  
heat recovery



Ventilation  
< 200 m<sup>3</sup>/h

# COMFORT CT150 / CT200

## Product description

Comfort CT150 / CT200 is an energy-efficient ventilation system with heat recovery for homes with a ventilation requirement of up to 200 m<sup>3</sup>/h. Comfort CT150 / CT200 is particularly suitable for newly-built or renovated flats, terraced house and summer cottages where the space is limited.

Comfort CT150 / CT200 is designed for vertical or horizontal mounting, which ensures flexible installation.

Comfort CT150 / CT200 is factory tested and ready for use. Installation and commissioning must be performed by an authorized electrician.



## Flexible unit

Comfort CT150 / CT200 can be fitted horizontally, vertically and at an angle, which means that it is flexible and can be used in many different applications.



## Project model

Comfort CT150 / CT200 is also available as a project model with CTS602 control.

A project model has all connections on the side of the unit. It saves time on installation and there is no need for an electrician to connect external components as for instance a cooker hood, heating elements and valves.

Comfort CT150 / CT200 offers a choice of control units:

CTS400 - a control unit with a simple control panel and many functions.  
CTS602 - an advanced control unit with a very user-friendly HMI touch panel.

Efficient counterflow heat exchanger providing high temperature efficiency and low pressure loss, resulting in good heat recovery and low energy consumption.

With built-in humidity control system for ventilation on demand. Low speed ventilation at low humidity levels and high speed ventilation at high humidity levels (e.g. a bath).

The automatic 100% bypass damper makes the outdoor air bypass the heat exchanger when heat recovery is not required, thereby saving energy.

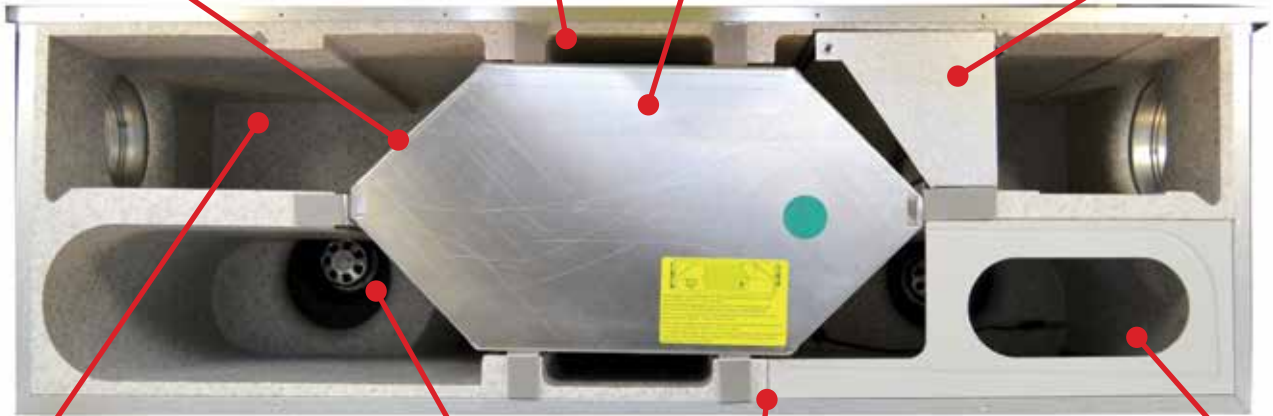

Time-controlled filter change alarm.  
Easy filter replacement: to open front panels, loosen finger screws. There is plenty of space to replace filters and vacuum the filter space.  
Visual alarm for filter change.

Flexible condensate drain design means that the system can be fitted horizontally, vertically or at an angle.

Chamber fan with B-wheel runs on energy-saving EC motors.

Stepless regulation at four different levels.

Comfort CT150 / CT200 is built of an aluzinc housing with an EPS hub. The EPS material is easy to shape so that air is led smoothly through the system, and therefore consumes as little energy as possible.

User APP solution via gateway  
LAN / WiFi is available as an accessory



# TECHNICAL DATA

## Comfort CT150

Dimensions (W x D x H) (*1)	1040 x 535 x 338 mm
Weight	30 kg
Plate type casing	Aluzinc steel plate
Heat exchanger type	Polyethylenerephthalat counterflow heat exchanger
Fan type	EC, constant rotation
Filter class	ISO Coarse >90% (G4)
Duct connections	Ø 125 mm
Condensate drain	PVC, Ø20x1.5 mm
Leakage classification (*2)	A1

Supply voltage	230 V (±10 %), 50/60 HZ
Max. input/power	70 W/0.7 A
Tightness class	IP31
Standby power	3,4 W
Ambient temperature	-20/+40 °C
Heat loss (*3)	0.96 W/m²K
Heat loss classification	T2

\*1 338 mm with wall mounting

\*2 Testet according to EN13141-7

\*3 Testet according to EN1886

SEC* average climate	-42.7 kWh/(m².a)
SEC* cold climate	-82.1 kWh/(m².a)
SEC* warm climate	-17.5 kWh/(m².a)
SEC-Class	A+
Type	Two-way ventilation unit for residential
Type of drive	Variable speed drive
Type of heat recovery system	Recuperative (counterflow heatexchanger)
Thermal efficiency of heat recovery	91,9 %
Maximum flow rate	175 m³/h (100 Pa)
Electric power input of fan drive, including any motor control equipment, at maximum flow rate	55.7 W
Sound power level L <sub>WA</sub>	49 dB(A)
Reference flow rate	0.034 m³/s (122.5 m³/h)
Reference pressure difference	50 Pa
SPI	0.163 W/(m³/h)
Central demand control	0.85
Maximum internal leakage	0.19 %
Maximum external leakage	0.35 %
Visual filter warning	An alarm on the user panel appears when filters need changing.  To maintain the performance and energy efficiency of the unit it is very important to change filters regularly.
Disassembly instructions	www.nilan.dk

AEC - annual electricity consumption	192 kWh/year (100 m²)
AHS** average climate	4681 kWh (100 m²)
AHS** cold climate	9157 kWh (100 m²)
AHS** warm climate	2117 kWh (100 m²)

\*\* Annual heating saved

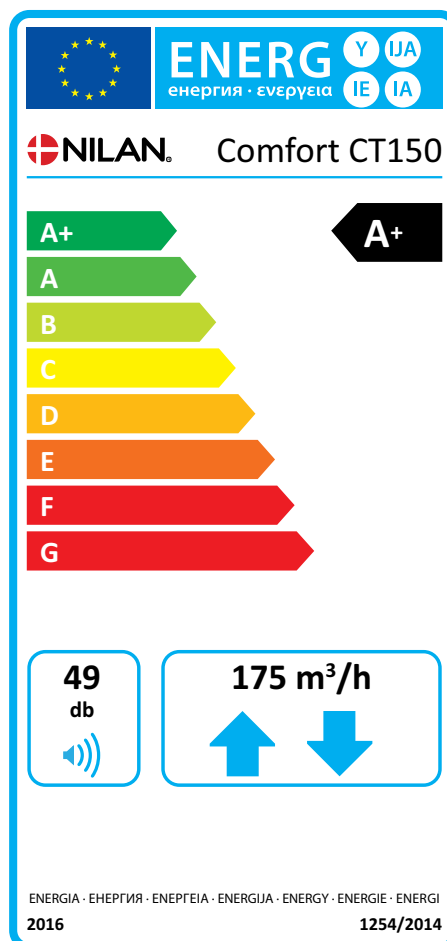

\* Specific energy consumption

## Dimensional drawing

All dimensions are in mm.

Comfort CT150 shown with inlet to the primary side (exchanger) and connection towards the left.

Left version:

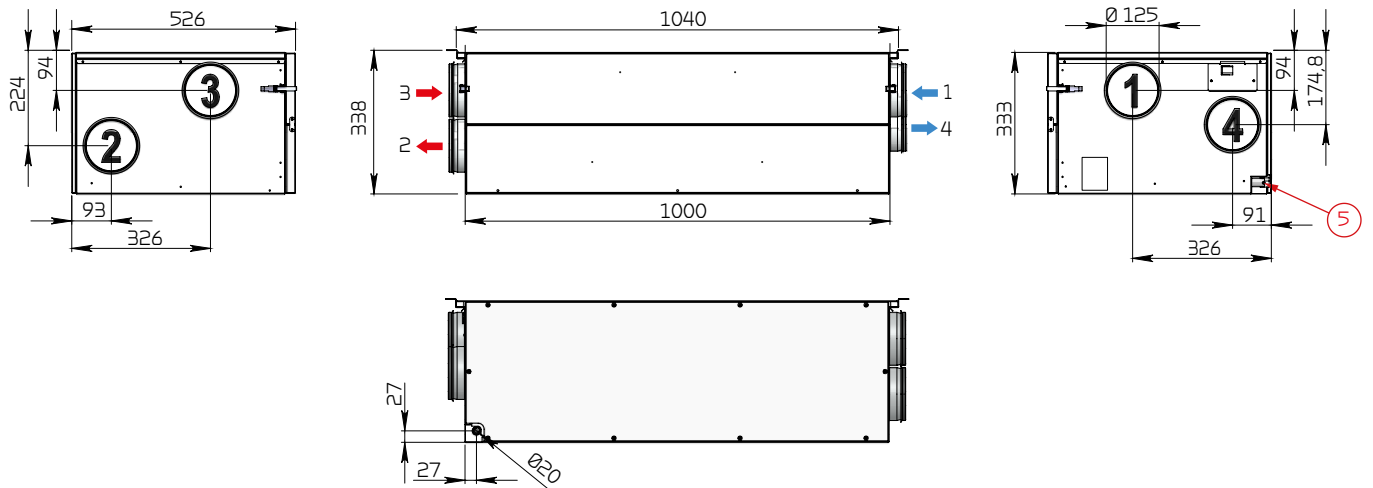

### Connections

- 1: Fresh air
- 2: Supply air
- 3: Extract air
- 4: Discharge air
- 5: Condensation drain

Right version:

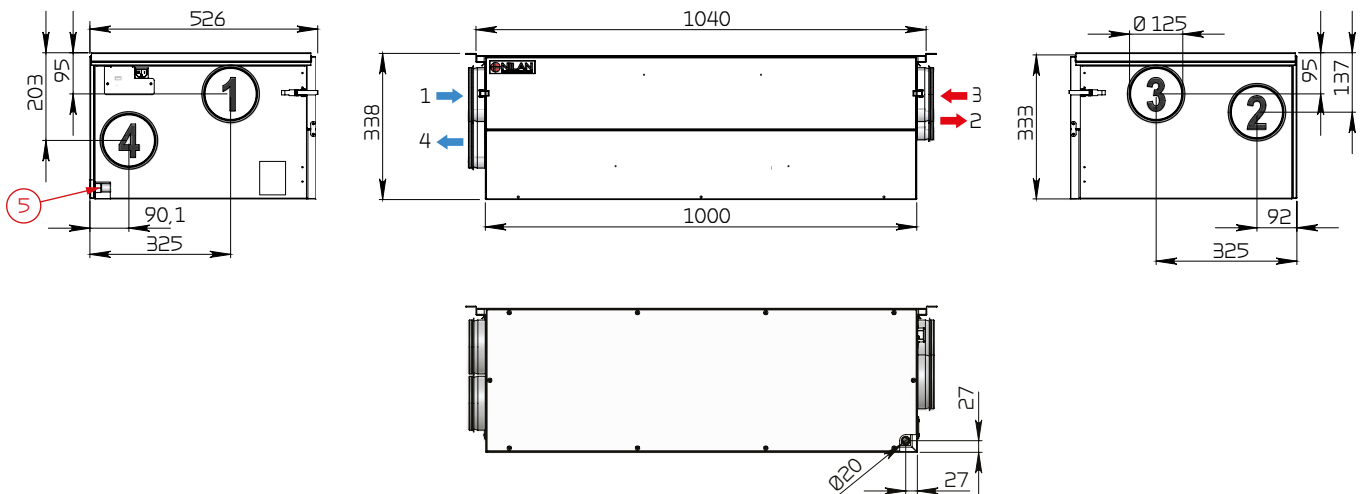

# PLANNING DATA

## Capacity

Capacity of standard unit as a function of  $q_v$  and  $P_{t,ext}$ .

SEL values according to EN 13141-7 are for standard units with ISO Coarse >90% (G4) filters and without heating element.

SEL values comprise the unit's total power consumption excl. control.

Testet according to EN 13141-7

Attention! The SEL values are measured and stated as a total value for both fans.

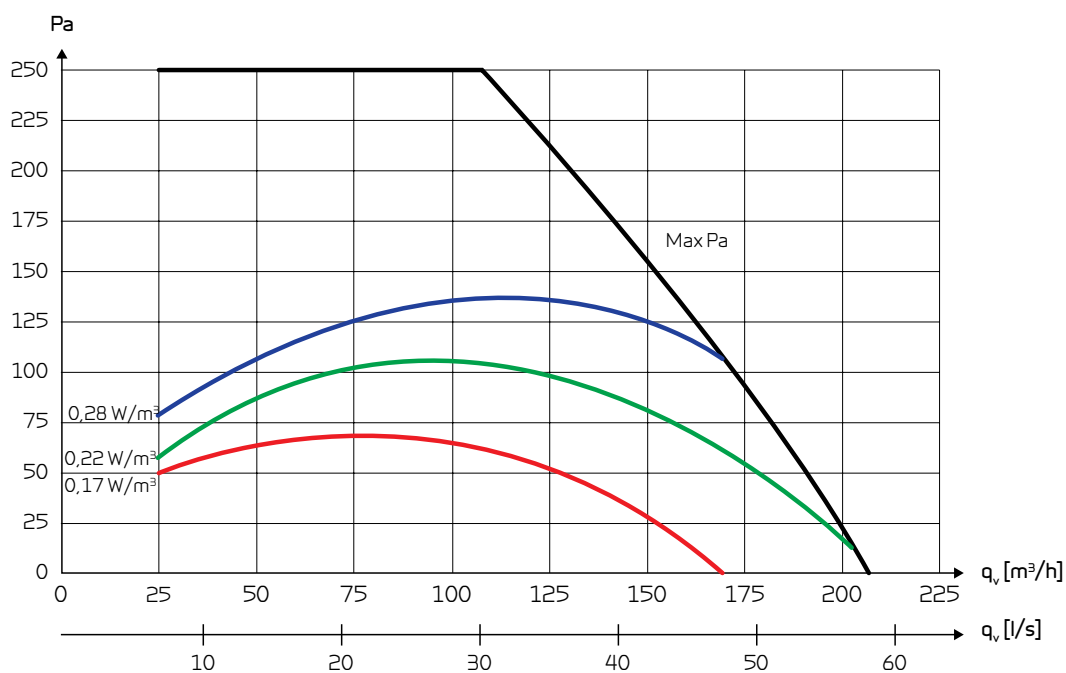

## Temperature efficiency

Temperature efficiency for units with counterflow heat exchanger according to EN308 and EN13141.7 (dry).

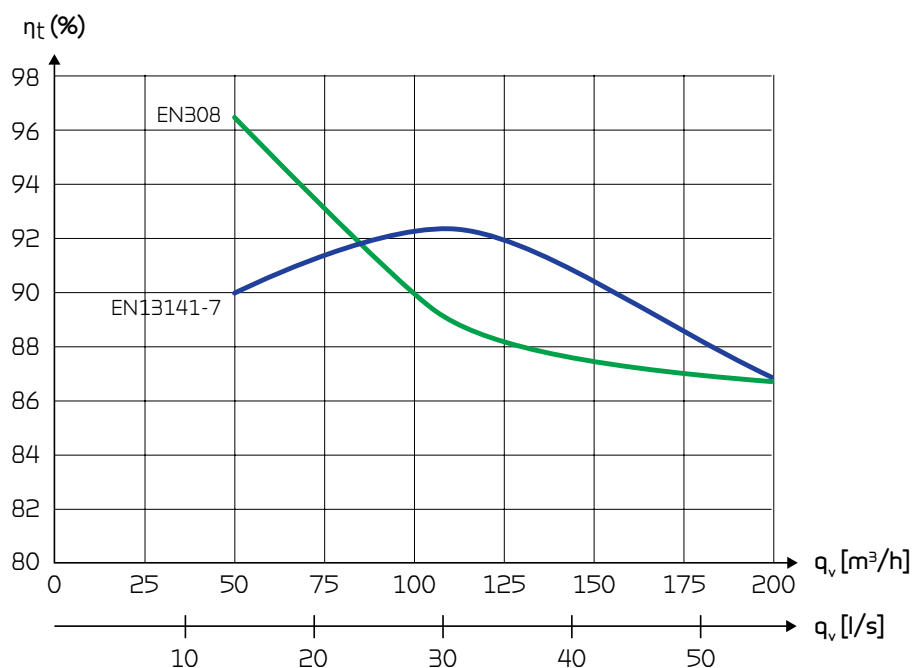

## Sound data

Sound data for  $q_v = 126 \text{ m}^3/\text{h}$  and  $P_{t, \text{ext}} = 75 \text{ Pa}$  according to EN 9614-2 for surfaces and EN 5136 for ducts.

Sound output level  $L_{\text{WA}}$  drops with falling air volume and falling back pressure.

Sound pressure level  $L_{\text{pA}}$  in a semi-hemisphere at a distance of 1 m from the system.

### Sound output level ( $L_{\text{WA}}$ )

Octave band Hz	Surface dB(A)	Supply air dB(A)	Extract air dB(A)
63		55	36
125		38	35
250		46	38
500		51	26
1.000		48	32
2.000		39	26
4.000		33	14
8.000		21	23
Total $\pm 2 \text{ dB(A)}$	46,2	57,5	42,1
$L_{\text{pA}}$	38		

## Sound data

Sound data for  $q_v = 175 \text{ m}^3/\text{h}$  and  $P_{t, \text{ext}} = 75 \text{ Pa}$  according to EN 9614-2 for surfaces and EN 5136 for ducts.

Sound output level  $L_{\text{WA}}$  drops with falling air volume and falling back pressure.

Sound pressure level  $L_{\text{pA}}$  in a semi-hemisphere at a distance of 1 m from the system.

### Sound output level ( $L_{\text{WA}}$ )

Octave band Hz	Surface dB(A)	Supply air dB(A)	Extract air dB(A)
63		40	34
125		53	38
250		60	53
500		65	56
1.000		60	45
2.000		60	40
4.000		63	39
8.000		51	11
Total $\pm 2 \text{ dB(A)}$	51,6	69,3	58
$L_{\text{pA}}$	44		

# TECHNICAL DATA

## Comfort CT200

Dimensions (W x D x H) (*1)	1040 x 535 x 338 mm
Weight	30 kg
Plate type casing	Aluzinc steel plate
Heat exchanger type	Polyethylenterephthalat counterflow heat exchanger
Fan type	EC, constant rotation
Filter class	ISO Coarse >90% (G4)
Duct connections	Ø 125 mm
Condensate drain	PVC, Ø20x1.5 mm
Leakage classification (*2)	A1

Supply voltage	230 V (±10 %), 50/60 HZ
Max. input/power	70 W/0.7 A
Tightness class	IP31
Standby power	3,4 W
Ambient temperature	-20/+40 °C
Heat loss (*3)	0.96 W/m²K
Heat loss classification	T2

\*1 338 mm with wall mounting

\*2 Testet according to EN13141-7

\*3 Testet according to EN1886

SEC* average climate	-41.5 kWh/(m².a)
SEC* cold climate	-80.7 kWh/(m².a)
SEC* warm climate	-16.4 kWh/(m².a)
SEC-Class	A
Type	Two-way ventilation unit for residential
Type of drive	Variable speed drive
Type of heat recovery system	Recuperative (counterflow heatexchanger)
Thermal efficiency of heat recovery	91,3 %
Maximum flow rate	200 m³/h (100 Pa)
Electric power input of fan drive, including any motor control equipment, at maximum flow rate	70 W
Sound power level L <sub>WA</sub> )	49 dB(A)
Reference flow rate	0.039 m³/s (140 m³/h)
Reference pressure difference	50 Pa
SPI	0.209 W/(m³/h)
Central demand control	0.85
Maximum internal leakage	0.19 %
Maximum external leakage	0.35 %
Visual filter warning	An alarm on the user panel appears when filters need changing.  To maintain the performance and energy efficiency of the unit it is very important to change filters regularly.
Disassembly instructions	www.nilan.dk

AEC - annual electricity consumption	235 kWh/year (100 m²)
AHS** average climate	4665 kWh (100 m²)
AHS** cold climate	9126 kWh (100 m²)
AHS** warm climate	2109 kWh (100 m²)

\*\* Annual heating saved

The image shows an energy label for the NILAN Comfort CT200. At the top, it features the European Union flag and the word 'ENERG' in large letters, with 'енергия · ενεργεια' and 'IE IA' below it. The brand name 'NILAN' and model 'Comfort CT200' are prominently displayed. The energy efficiency class is shown as 'A' in a black box, with a scale from A+ (green) to G (red) on the left. Below this, the sound power level is indicated as '49 db' with a speaker icon. The maximum flow rate is shown as '200 m³/h' with two arrows pointing up and down. At the bottom, the text 'ENERGIA · ЕНЕРГИЯ · ΕΝΕΡΓΕΙΑ · ENERGIJA · ENERGY · ENERGIE · ENERGI' is written, along with the year '2016' and the standard number '1254/2014'.

\* Specific energy consumption

## Dimensional drawing

All dimensions are in mm.

Comfort CT200 shown with inlet to the primary side (exchanger) and connection towards the left.

Left version:

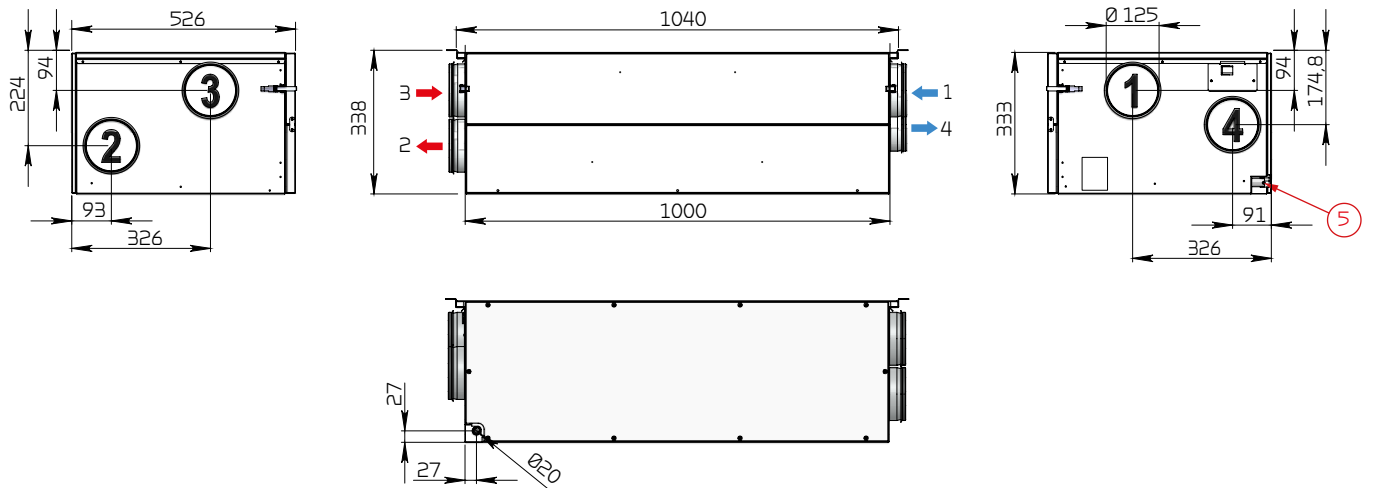

### Connections

- 1: Fresh air
- 2: Supply air
- 3: Extract air
- 4: Discharge air
- 5: Condensation drain

Right version:

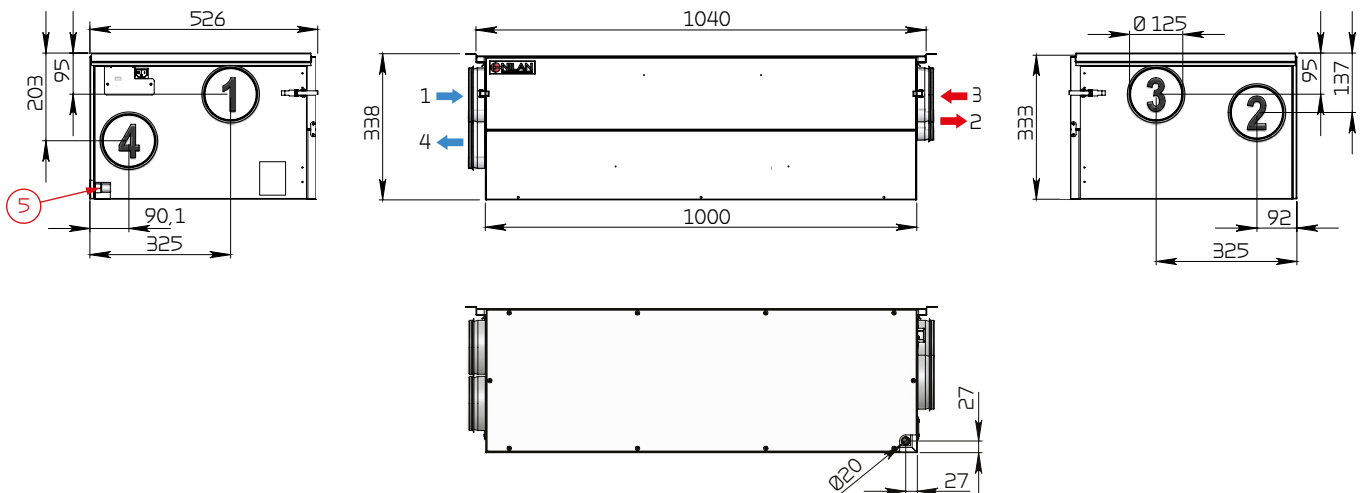

# PLANNING DATA

## Capacity

Capacity of standard unit as a function of  $q_v$  and  $P_{t,ext}$ .

SEL values according to EN 13141-7 are for standard units with ISO Coarse >90% (G4) filters and without heating element.

SEL values comprise the unit's total power consumption excl. control.

Tested according to EN 13141-7

Attention! The SEL values are measured and stated as a total value for both fans.

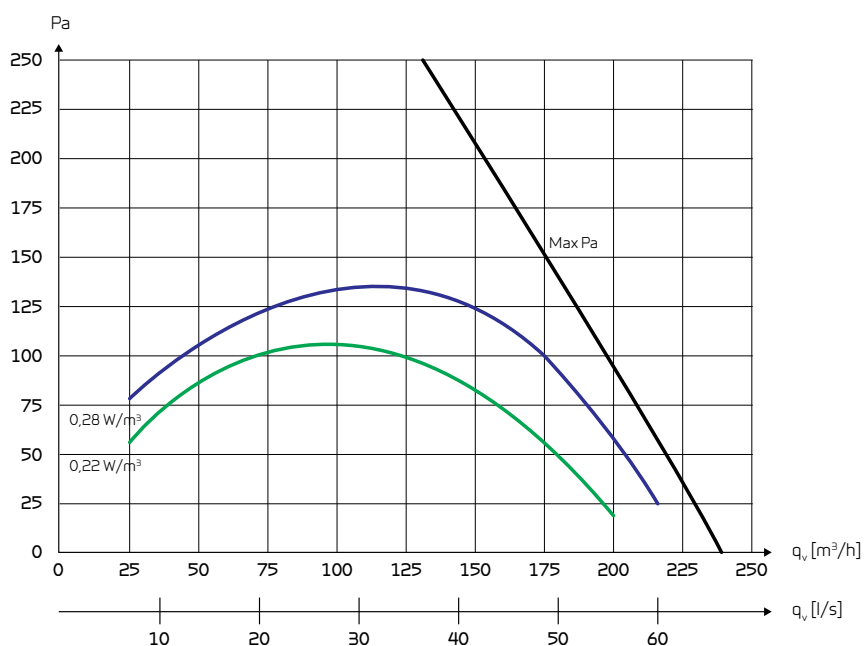

## Temperature efficiency

Temperature efficiency for units with counterflow heat exchanger according to EN308 and EN13141,7 (dry).

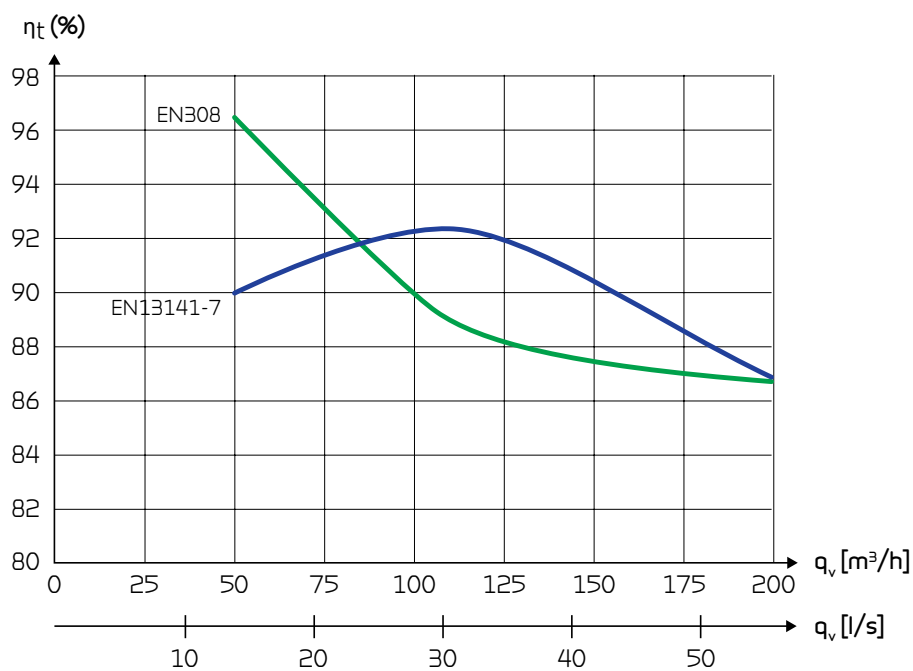

## Sound data

Sound data for  $q_v = 126 \text{ m}^3/\text{h}$  and  $P_{t, \text{ext}} = 75 \text{ Pa}$  according to EN 9614-2 for surfaces and EN 5136 for ducts.

Sound output level  $L_{\text{WA}}$  drops with falling air volume and falling back pressure.

Sound pressure level  $L_{\text{pA}}$  in a semi-hemisphere at a distance of 1 m from the system.

### Sound output level ( $L_{\text{WA}}$ )

Octave band Hz	Surface dB(A)	Supply air dB(A)	Extract air dB(A)
63		55	36
125		38	35
250		46	38
500		51	26
1.000		48	32
2.000		39	26
4.000		33	14
8.000		21	23
Total $\pm 2 \text{ dB(A)}$	46,2	57,5	42,1
$L_{\text{pA}}$	38		

## Sound data

Sound data for  $q_v = 175 \text{ m}^3/\text{h}$  and  $P_{t, \text{ext}} = 75 \text{ Pa}$  according to EN 9614-2 for surfaces and EN 5136 for ducts.

Sound output level  $L_{\text{WA}}$  drops with falling air volume and falling back pressure.

Sound pressure level  $L_{\text{pA}}$  in a semi-hemisphere at a distance of 1 m from the system.

### Sound output level ( $L_{\text{WA}}$ )

Octave band Hz	Surface dB(A)	Supply air dB(A)	Extract air dB(A)
63		40	34
125		53	38
250		60	53
500		65	56
1.000		60	45
2.000		60	40
4.000		63	39
8.000		51	11
Total $\pm 2 \text{ dB(A)}$	51,6	69,3	58
$L_{\text{pA}}$	44		

# OPERATION

## Intelligent humidity control

Nilan's humidity control automatically adapts to the needs of inhabitants or the building itself.

The intelligent CTS400 / CTS602 control unit does not require a set air humidity level (RH) to manage the air exchange. Using the integrated humidity sensor, the control unit calculates the average humidity over the past 24 hours and regulates the air flow accordingly.

Consequently the unit's efficiency is based on actual instead of theoretical air humidity levels.

Automatically adapting to air volume requirements saves energy as the number of persons in a home is relevant as to how much humidity is produced.

The unit also adjusts automatically to summer and winter levels.

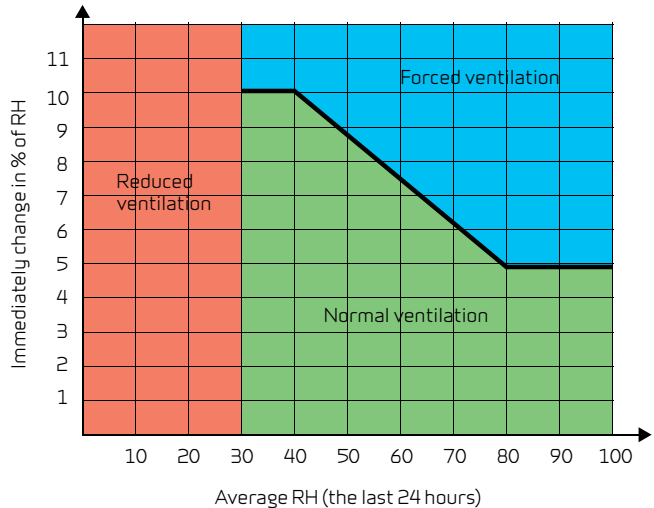

*If the air humidity changes by more than 5-10% in relation to the average level, the unit responds with a higher rate of air exchange accordingly.*

*When air humidity falls below 30%, ventilation scales back automatically. The percentage is adjustable from 15 - 45%.*

## Functional diagram

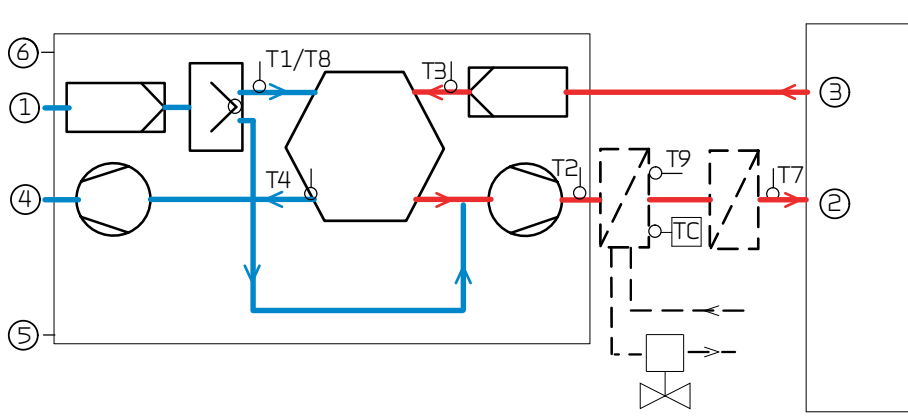

### Automation

- T2/T7: Supply air sensor
- T9: Heating element
- T3: Extract air sensor
- T4: Discharge air and defrost sensor
- T8: Fresh air sensor

### Connections

- 1: Fresh air
- 2: Supply air
- 3: Extract air
- 4: Discharge air
- 5: Condensate drain
- 6: Electric and water heating

## Capacity - Heating element (accessory CTS400 / CTS602)

When connecting a heating element, a Comfort CT150 / CT200 must be ordered as a project model. A project model has all connections on the side of the unit.



### Electrical heating element

The electrical heating element is fitted in the supply air duct at a distance of min. 2 x duct diameter from the system's fresh air connection pipe (normally min 250 mm.) and connected to the CTS400 / CTS602 control panel and 230 V supply.

The electrical heating element can supply up to 0,6 kW of heat.



### Water heating element for duct fitting

The water heating element is designed to be built into the duct and must be connected to the primary heating supply and the CTS400 / CTS602 control. The water heating element includes copper pipes and aluminium fins.

Capacities can be seen in the table below.

#### Capacity water heating element

Temperature input/output [°C]	Water side			Air side			
	Flow [m³/h]	Pressure drop [kPa]	Output [kW]	Flow [m³/h]	Temperature before WHE* [°C]	Temperature after WHE* [°C]	Pressure drop over WHE* [Pa]
40/30	0,04	0,85	0,52	100	16	31,1	2
	0,06	1,25	0,64	135	16	29,8	3
60/40	0,04	0,69	0,94	100	16	43,5	2
	0,05	1,00	1,16	135	16	41,1	3
70/40	0,03	0,40	1,06	100	16	47,0	2
	0,04	0,58	1,30	135	16	44,2	3

\* Water heating element.

# AUTOMATION CTS400

## CTS400 Control



CTS400 is a simple and intuitive control panel with a complex control system that contains many useful functions. On the control panel you can set the fan speed level, turn the unit on and off and see potential alarms.

When installed in rental properties, hotels etc., you can lock the panel so tenants cannot turn off the unit and/or alter the fan speed level.

The many functions of the control system enable you to connect, for instance, after-heating elements and a CO<sub>2</sub> or VOC sensor. The control system includes, as standard, user selection programs, an intelligent humidity control system and an integral fire automation system.

CTS400 has open Modbus communication that enables connection to external CTS systems.

The Modbus connection can also be connected to a Nilan gateway cloud solution that allows you to control and monitor the unit via a smartphone APP solution.

Functions overview		+ Standard - Accessories
Filter monitor	Filter alarm with timer (the default setting is 90 days). You can set this to anything between 1 - 360 days.	-
100 % bypass	The air will bypass the heat exchanger if heat recovery is not required.	+
Humidity control system	Enables a higher or lower fan speed level at a high/low level of humidity.	+
Summer/winter mode	Setting for when the unit is to operate in summer or winter mode respectively.	+
Stop at low room temperature	Stops ventilation at low room temperature if, for instance, the heat supply fails.	+
De-icing	Automatic function that de-ices the exchanger based on temperature.	+
Temperature control	Controls the bypass and potential after-heating elements in accordance with the selected room temperature.	+
Air volume	Enables stepless setting of four fan speed levels for supply air and extract air.	+
CO <sub>2</sub> / VOC control system	Enables the addition of an external CO <sub>2</sub> or VOC control system.	-
Fire automation system	Enables the addition of a fire automation system to control 1-2 fire dampers.	-
Electrical after-heating element	Enables the addition of an electrical after-heating element.	-
Water after-heating element	Enables the addition of a water after-heating element.	-
User selections 1 and 2	User selection is used for external potential free control signals from, for instance, a cooker hood.	+
Fire thermostat/ external fire automation system	You can connect a fire thermostat or an external fire automation system.	+
Locking the control panel	You can lock the control panel so it cannot be turned off and/or the fan speed level cannot be altered.	+

## External communication

The CTS400 control unit communicates by default with Modbus RTU RS485 communication. A CTS system using this form of communication can easily be connected to the unit.

Nilan units have an open Modbus communication, i.e. not only can the unit be monitored, but its operation can also be set in the same way as it can via the operating panel.

The protocol is by default set up for a Modbus RTU30 address; however, values can be set between 1 and 247.

A Modbus converter allows you to connect one or more units to a computer to monitor and control the unit.

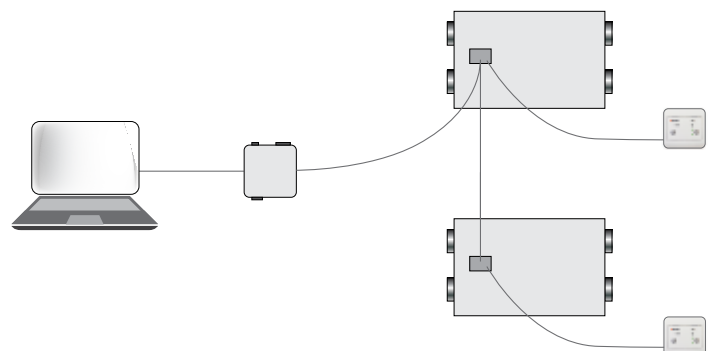

## PC-Tool

Nilan provides a PC tool for creating settings and for balancing the unit. This gets installed in the installer's computer. Via a USB connection on the outside of the unit it is then connected to the circuit board for the unit.

The selected settings can be saved to the installer's computer and can be copied to another unit where the same settings are required. If necessary, PC Tool also allows the installer to update the software in the unit.

The user has no access to alter the settings via PC Tool.

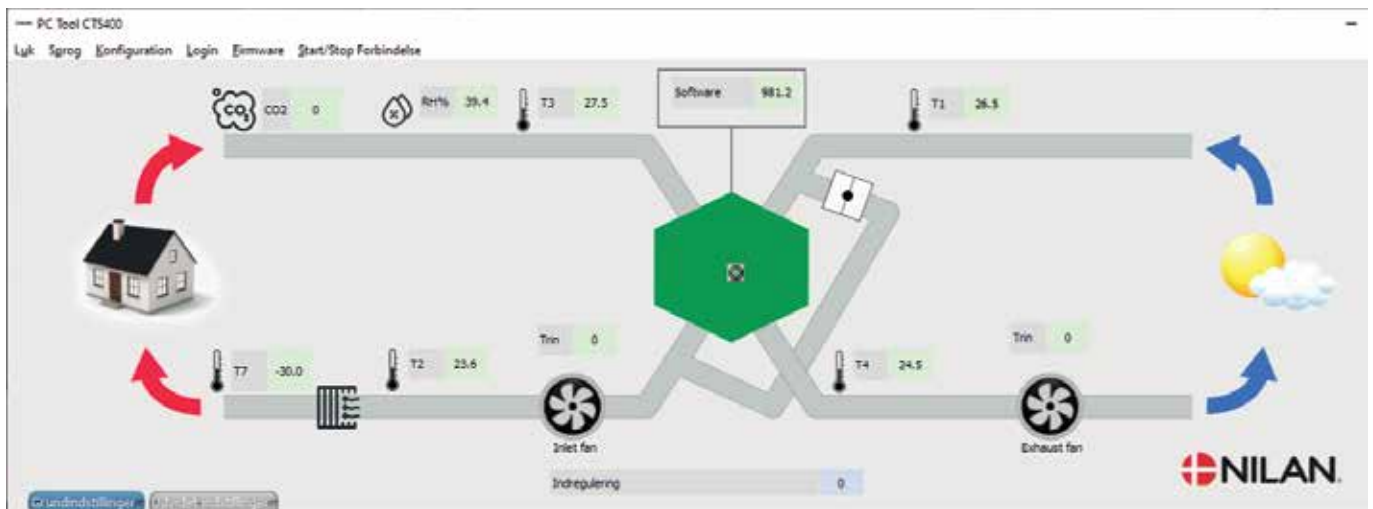

## Nilan User APP

By purchasing a Nilan gateway, the user can gain access to the unit via a Nilan User APP. The APP enables the user to access and monitor the current operation, also from the outside of the property. The APP allows you to adjust the default settings of, for instance, room temperature, fan speed level and the humidity control system.

The APP shows when filter change is next due. This is an important function, and you are automatically notified when filters need changing or an alarm is triggered.

It also provides you with useful trend curves so you can follow the operation of the unit for the previous week with regards to, for instance, room temperature or humidity level.

Using a LAN connector, you connect the gateway to the Modbus of the unit and then to the user's internet router via a LAN or a WiFi connection. This creates a secure cloud connection between the unit and the smartphone.



# AUTOMATION CTS602

## CTS602 Control

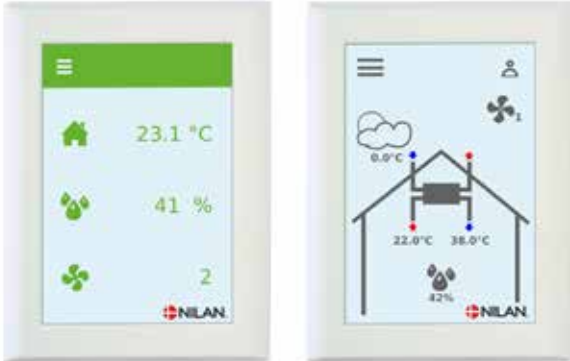

The CTS602 HMI touch panel is featuring a wide range of functions, e.g., menu-controlled operation, weekly programme settings, filter monitor with timer, fan speed adjustment, summer bypass (free cooling), supply-heating element control, error messages etc.

The CTS602 comes with factory settings, including a default setting which can be customised to operational requirements to achieve optimum operation and utilisation of the system.

There is an option for selecting between 2 front page images for the main screen.

Operating instructions for the CTS 602 can be found in a separate user manual supplied with the unit.

## Nilan User APP

By purchasing a Nilan gateway, the user can gain access to the unit via a Nilan User APP. The APP enables the user to access and monitor the current operation, also from the outside of the property.

The APP allows you to adjust the default settings of, for instance, room temperature, fan speed level and the humidity control system.

The APP shows when filter change is next due. This is an important function, and you are automatically notified when filters need changing or an alarm is triggered.

It also provides you with useful trend curves so you can follow the operation of the unit for the previous week with regards to, for instance, room temperature or humidity level.

Using a LAN connector, you connect the gateway to the Modbus of the unit and then to the user's internet router via a LAN or a WiFi connection. This creates a secure cloud connection between the unit and the smartphone.



## External communication

The CTS602 control unit communicates by default with Modbus RTU RS485 communication. A CTS system using this form of communication can easily be connected to the unit.

Nilan units have an open Modbus communication, i.e. not only can the unit be monitored, but its operation can also be set in the same way as it can via the operating panel.

The protocol is by default set up for a Modbus RTU30 address; however, values can be set between 1 and 247.

A Modbus converter allows you to connect one or more units to a computer to monitor and control the unit.

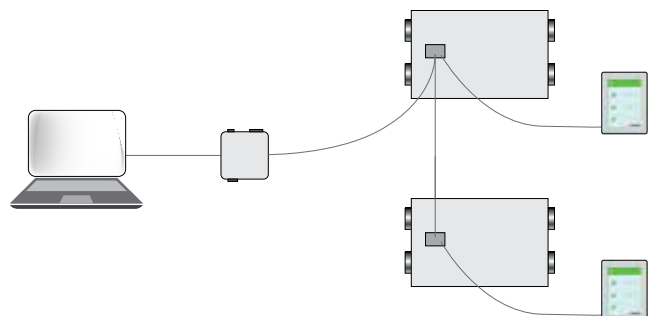

Functions overview		+ Standard - Accessories
Alarms	Description of errors indicated with alarms. Alarm log displaying the latest 16 alarms.	+
Joint alarm	The CTS602 control system has an output signal that is activated in the case of an alarm. It can be connected to, for example, external automation.	
Filter monitor	Filter alarm with timer that can be set to 30/90/180/360 days.	+
Data display	An overview of the current operation with regards to temperatures, fan speed level etc.	+
Week program	The CTS602 control system has 3 week programs that can be set individually (the default setting is "off").	+
Humidity control system	Enables a higher or lower degree of ventilation at a high/low level of humidity.	+
Air quality	Enables you to adjust the degree of ventilation depending on the CO <sub>2</sub> level in the air.	-
Winter low	You can prevent a low level of humidity in the dwelling by activating low ventilation at low outdoor temperatures.	+
Temperature regulation	Enables you to control the operation of the unit in accordance with the room temperature.	+
Summer/winter mode	You can set the unit to operate in summer or winter mode.	
Language	You can choose from more than 10 languages in the control panel.	+
User levels	The menu in the control panel is divided into 3 user levels: User/Installer/Factory.	+
User selection 1	Enables you to override the operating mode via an external potential free signal.	+
User selection 2	Enables you to override the operating mode as well as user selection 1 via an external potential free signal.	-
Electrical after-heating element	An electrical after-heating element allows you to control the supply air temperature. In this way the unit can help heat the dwelling.	-
Water after-heating element	A water after-heating element allows you to control the supply air temperature. In this way the unit can help heat the dwelling.	-
Frost protection	In order to protect a potential water after-heating element against frost damage, the unit will stop and display an alarm if the temperature in the water after-heating element becomes too low.	-
Air exchange	Stepless setting of four fan speed levels. The supply air and the extract air can be set individually.	+
De-icing	Based on temperature, this automatic function de-ices the counterflow heat exchanger if ice has formed within it.	+
Room low	Safety function that will cause the ventilation unit to stop if the heating system for the dwelling fails. This will prevent the unit from cooling the dwelling even further.	+
External heating	The ventilation unit can control an external heat supply in accordance with the current room temperature.	+
External fire automation system	You can connect the ventilation unit to an external fire automation system or to a fire thermostat. This will signal to the unit whether to stop or continue operation.	+
Integral fire automation system	The ventilation unit is available with an integral fire automation system that can control fire and smoke dampers.	-
Pressure sustaining regulator	You can install a pressure sustaining regulator on the side of both the extract air and the supply air (applies to CTS602 control - not CTS602 light).	-
Delayed start-up	You can activate a delayed start-up of the fans if you install, for instance, a shut-off damper.	+
Restore settings	You can save the current settings and subsequently restore them if, for instance, the user has altered the settings on the unit. You can also reinstall the default settings.	+
Manual operation	Different functions can be tested manually.	+
Energy saving function	You can activate a power saving function of the operation.	+
Modbus	You can set the Modbus address of the unit. The default setting is 30.	+
Data logging	It is possible to log the operational data of the unit every 1 - 120 min. Alarms are logged when they occur.	+
Control panel	You can choose from 2 different images for the main screen.	+

You can find further information about all the functions in the Software and Installation instructions for the unit.

# ACCESSORIES CTS400 / CTS602



## Electrical pre-heating element (Frost protection)

To prevent the highly efficient counterflow heat exchanger from freezing, we recommend that you fit an electrical pre-heating element. The element consumes very little energy but improves heat recovery. The net result is more cost-efficient operation.



## EM-box

The EM-box distributes extract air between kitchen and bathroom. If the range hood runs via the ventilation system and is operating, extract air flow from the bathroom is reduced to ensure that there is enough air to allow the cooker hood to extract cooking odours. To protect the system, the EM-box is fitted with a metal filter, which efficiently eliminates fat particles from range hood air.



## DBTU damper

If there is not enough space to fit an EM-box, Nilan offers a DTBU damper, which can be fitted between kitchen and bathroom. The damper functions precisely like the EM-box but requires longer cables.



## Cooker hood filter box

If the extract air needs extra filtration, Nilan can supply a Cooker hood filter box. This can provide extra protection of the ventilation unit if you connect a cooker hood that has not got good filters. It can also help air extraction from, for instance, dormitory rooms where cooker hoods are rarely installed.



## Connection box

A "Connection box" has the following connection options: Connection of 1-2 fire dampers, external fire thermostat, user selection 1 (cooker hood) and Modbus communication to, for instance, CTS unit.



## Water trap

To prevent "false" air being sucked into the system via the condensate drain, the system must be fitted with a water trap. While there is water in the condensate drain, the water trap works well. However, during the summer months when there is no condensation of extract air, the water trap will dry out (and therefore cease to prevent "false" air intake). A Nilan water trap with ball prevents "false" air flow all year round.



## Heating cable

To protect the condensation outlet against frost, a 3 or 5 metre-long self-regulating heating cable can be ordered.



## Vibration absorbers

It is important to ensure that the ventilation unit does not transfer vibrations to the building. The ventilation unit should therefore be placed on a vibration absorbing material. Nilan can supply effective vibration absorbers to place under the ventilation unit. They are sold in packs of 4.



## Flexible silencing

For easy fitting and excellent noise reduction between the system and the distribution box and/or between the system and roof vents.



## Pollenfilter ISO ePM1 50-65% (F7)

Comfort CT150 / CT200 is as standard with ISO Coarse >90% (G4) filter delivered. If someone in the housing suffers from pollen allergy, it is possible to order a pollenfilter ISO ePM1 50-65% (F7) to minimize the amount of Pollen in the supply-air.



## Gateway with APP solution

Comfort CT150/CT200 can be controlled with a smartphone APP via a gateway connection. Connect the Nilan Gateway to the CTS400 or the CTS602 control system. This allows for a cloud connection to the unit. The gateway is available in two different versions - with either a LAN or a WiFi connection to a router.



## Spacing bracket, vertical installation

For vertical installation, a wall bracket can be attached to lead and conceal the ducts. This converts the unit to a top unit. The side panels are prepared for mounting of the display panel.



## Rear mounting brackets for vertical mounting

A wall bracket can be purchased and attached for mounting on the back of the unit. By vertical mounting the unit works as a top-unit.

# ACCESSORIES CTS400



## Electrical heating element incl. regulation

When fitting an electrical heating element, fresh air temperatures can be raised to desired levels at any time. The electrical heating element is supplied ready to fit into the fresh air duct and, for easy fitting, the device is pre-fitted with all the required sensors (*supplied with a connection box*).



## Water heating element incl. regulation

The supply temperature can always be raised to the required level using a water heating element. The water heating element is designed to be built into the duct and must be connected to the primary heating supply. Supplied with two-way adjustment valve, temperature sensor and frost thermostat (*supplied with a connection box*).



## Connection box for CTS400

Connect the following external functions to the ventilation unit via a connection box with a RJ45 connector: User selection 1 and 2, Modbus communication, Fire thermostat or external fire automation system. A wire of 0.5 m runs from the box to an RJ45 connector that you connect directly to the ventilation unit.



## Electrical heating element incl. regulation

When fitting an electrical heating element, fresh air temperatures can be raised to desired levels at any time. The electrical heating element is supplied ready to fit into the fresh air duct and, for easy fitting, the device is pre-fitted with all the required sensors (*expansion PCB included*).



## Water heating element incl. regulation

The supply temperature can always be raised to the required level using a water heating element. The water heating element is designed to be built into the duct and must be connected to the primary heating supply. Supplied with two-way adjustment valve, temperature sensor and frost thermostat (*expansion PCB included*).



## Expansion PCB

The expansion PCB provides additional functions for the CTS602 control unit.



## Extension cable HMI control panel

The control panel for the ventilation unit is connected up with a short wire so it can be installed close to the unit. If you place the unit so the control panel is out of sight, for instance in a cupboard or in the loft, you can order a 15 m extension cable with plug. This allows you to place the control panel where it is visible to the user.

It is important that the control panel is visible so the user can see alarms when, for example, filters need replacing.

# INSTALLATION OPTIONS

## Top installation (standard)

Comfort CT150 / CT200 is delivered with two strong installation rails, which can be fastened to the ceiling or wall with suitable rawlplugs and screws.

This ensures an easy installation of Comfort CT150 / CT200 because you do not have to support the unit when fastening. All you have to do is installed the two rails and afterwards the unit can easily be glided in to place.

1. Install the rails where the unit has to installed.

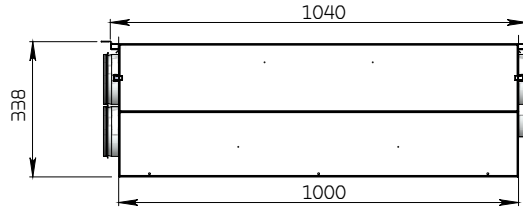

2. Glide the unit in to place in the rails

The ends of the rails are folded, and the unit is now in position

Comfort CT150 / CT200 can be installed:

- Horizontal
- Diagonal
- Vertical

With extract air and supply air to the left/upwards.

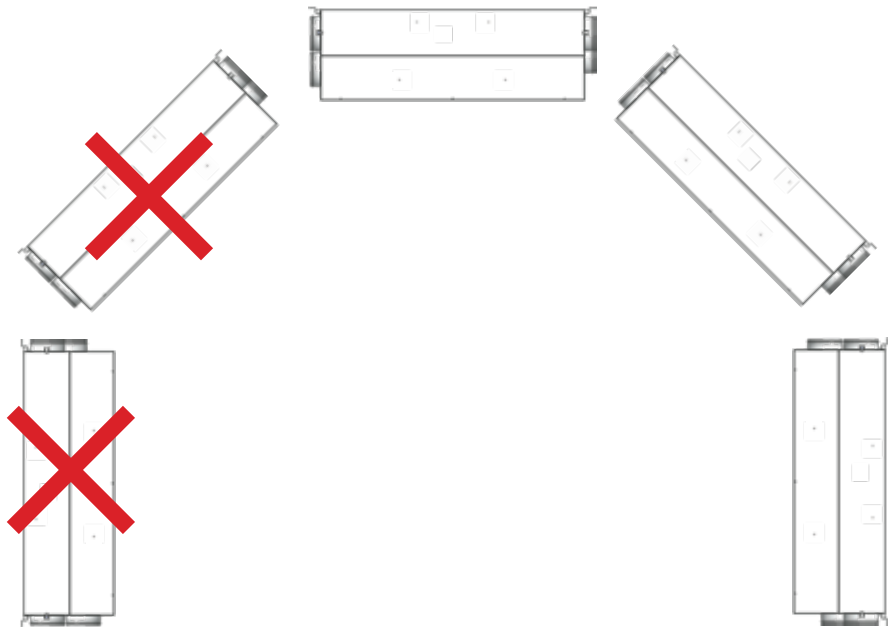

## Side installation

When installing Comfort CT150 / CT200 sideways is it possible to purchase a wall bracket, where ducts can be lead and be hidden and protected.

Like that is Comfort CT150 / CT200 transformed into a top unit. The side panels on the wall bracket is prepared for mounting of the display panel.

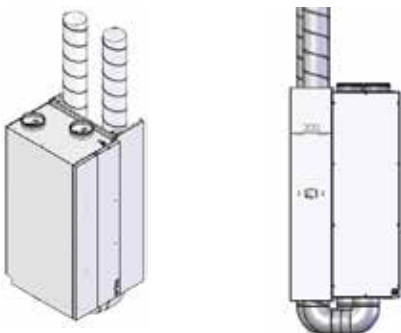

## Rear installation

When installing Comfort CT150 / CT200 on the back side is it possible to purchase a backside wall bracket. This ensures that there is enough space for the condensation drain.

Like that is Comfort CT150 / CT200 transformed into a top unit.

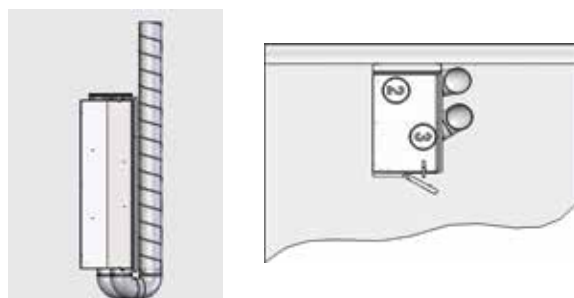

# DELIVERY AND HANDLING

## Transport and storage

Comfort CT150 / CT200 is shipped in protective packaging for transport and storage.

Comfort CT150 / CT200 must be stored in a dry place in its original packaging until installation.

The packaging should only be removed immediately prior to installation.

## Installation conditions

When replacing fans and PCBs, you have to dismantle the system. These components are accessible from the rear panel.

We recommend therefore that you fit Comfort CT150 / CT200 with flexible hose connections between the system and the ductwork, and that you fit the system so that it is simple and easy to take down from the brackets.

## Installation of electric heating element

Electric heating elements (accessories) are fitted in the duct.

The heating element must be insulated using fire-resistant insulation material.

The electric heating element must be connected by an authorised electrician.

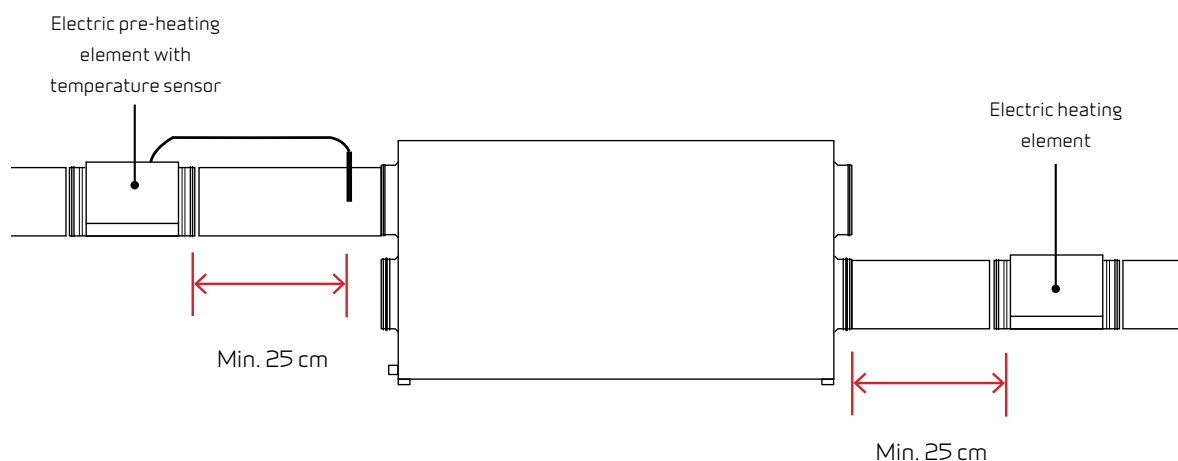

# INFORMATION FROM A TO Z

Nilan develops and manufactures premium-quality, energy-saving ventilation and heat pump solutions that provide a healthy indoor climate and low-level energy consumption with the greatest consideration for the environment. In order to facilitate each step in the construction process - from choosing the solution through to planning, installation and maintenance - we have created a series of information material which is available for download at [www.nilan.dk](http://www.nilan.dk).



**Brochure**  
General information about the solution and its benefits.



**Product data**  
Technical information to ensure correct choice of solution.



**Installation instructions**  
Detailed guide for installation and initial adjustment of the solution.



**User manual**  
Detailed guide for regulation of the solution to ensure optimum day-to-day operation.

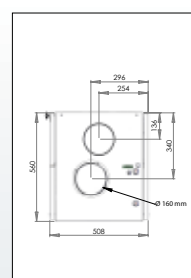

**Drawings**  
Tender documents and 3D drawings are available to download for planning purposes.

[WWW.NILAN.DK](http://WWW.NILAN.DK)

Visit us at [www.nilan.dk](http://www.nilan.dk) to find out more about our company and solutions, download further information and find your nearest dealer.



Nilan A/S  
Nilanvej 2  
8722 Hedensted  
Denmark  
Tel. +45 76 75 25 00  
Fax +45 76 75 25 25  
[nilan@nilan.dk](mailto:nilan@nilan.dk)  
[www.nilan.dk](http://www.nilan.dk)